

HUMIDITY & TEMPERATURE TRANSMITTER (4 to 20mA) HTM-420-D

HTM-420-D using HUMIREL HM1500LF voltage output humidity module and Pt-100 platinum resistance temperature detector (RTD) is a **dedicated 4 to 20mA relative humidity and temperature transmitter** designed for OEM applications. Humidity and temperature current outputs are linear with relative humidity and temperature. It features a small size and cost effective for humidity and temperature control applications.

SPECIFICATIONS

Humidity Measuring Range	0 to 100%RH
Storage Temperature	-40 to 105°C
Temperature Operating Range	-40 to 85°C
Supply Voltage	8 to 30Vdc
Current Consumption	Max. 30mA
Accuracy	±3%RH, ±0.3°C
Humidity Hysteresis	±1%RH
Load Resistance	0 to 750Ω
Humidity Sensor Element	Capacitive Type



HUMIDITY vs CURRENT OUTPUT TABLE @23°C

Humidity(%RH)	0	10	20	30	40	50	60	70	80	90	100
Current Output(mA)	4.00	5.60	7.20	8.80	10.40	12.00	13.60	15.20	16.80	18.40	20.00

TEMPERATURE vs CURRENT OUTPUT TABLE (-30 to 70°C or -20 to 80°C)

Temperature(°C)	-30	-20	-10	0	10	20	30	40	50	60	70
Current Output(mA)	4.00	5.60	7.20	8.80	10.40	12.00	13.60	15.20	16.80	18.40	20.00
Indicator Display	0	10	20	30	40	50	60	70	80	90	100

Temperature(°C)	-20	-10	0	10	20	30	40	50	60	70	80
Current Output(mA)	4.00	5.60	7.20	8.80	10.40	12.00	13.60	15.20	16.80	18.40	20.00
Indicator Display	0	10	20	30	40	50	60	70	80	90	100

HUMIDITY & TEMPERATURE TRANSMITTER (4 to 20mA) HTM-420-D

ELECTRICAL CONNECTION DIAGRAM

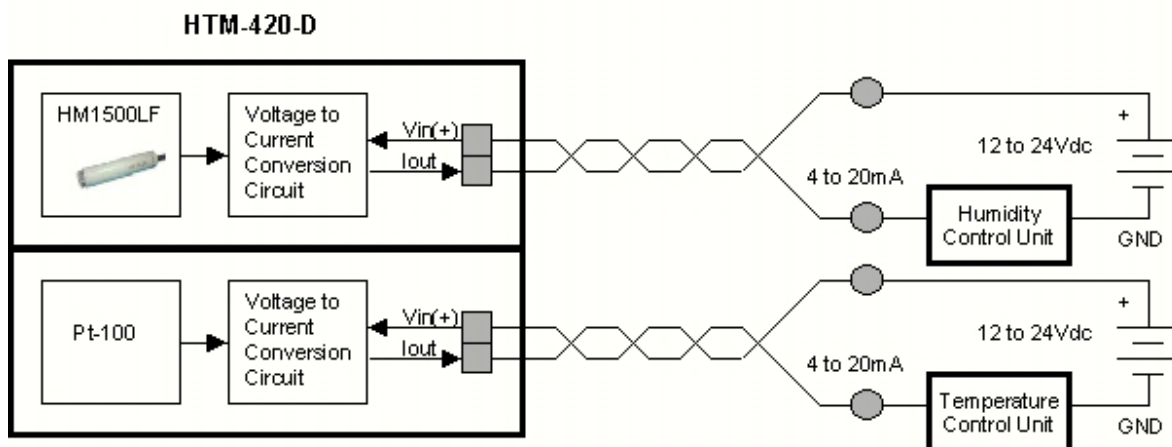

RESISTANCE to PHYSICAL and CHEMICAL STRESSES

- HM1500LF has passed through qualification processes of HUMIREL including vibration, shock, storage, high temperature and humidity, ESD.
- Additional tests under harsh chemical conditions demonstrate good operation in presence of atmosphere, SO₂(0.5%), H₂S(0.5%), O₃, NO_x, NO, CO, CO₂, Softener, Soap, Toluene, Acids (H₂SO₄, NH₃, HCl), HMDS, Insecticide, Cigarette smoke, a non exhaustive list.
- HM1500LF is not light sensitive.